

BODY SHOW

Magic Machine

A machine that enables movements while you are standing

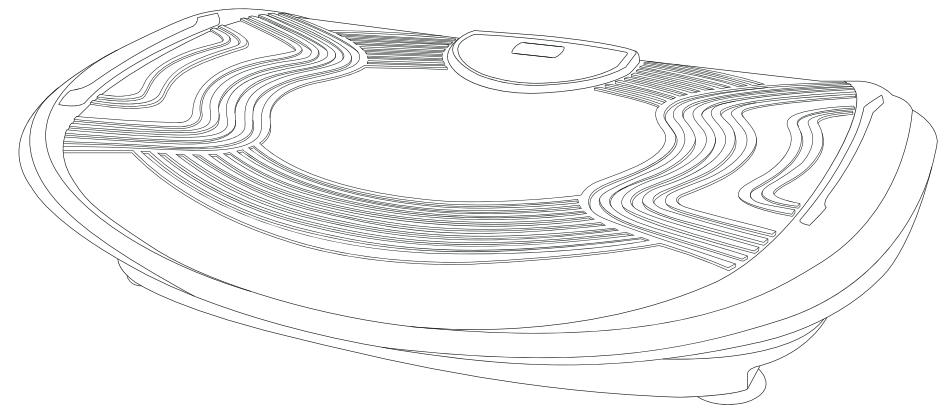

SAVE THESE INSTRUCTIONS

Products refer to the actual product, without prior notice.

Y21-1

OPERATION INSTRUCTIONS

Thanks for purchasing this product. Please read this manual instruction carefully in order to know how to use this product correctly before operation. Please pay more attention to some important safety warning and keep this manual book properly for future use.

Note: Our Company reserves the right to revise the design and description of this product without any further notice. Please refer to the actual color of this product.

CONTENTS

Safety And Maintenance	02
Name And Function	04
Operation guide	05
The method of usage	08
Automatic program guide	10
Maintenance/Remote control COMS installing	15
Troubleshooting/Specification	16

Safety And Maintenance

1. IMPORTANT SAFETY WARNING

- Do not allow any foreign matter to enter the clearance between the massage head and the casing
- Do not allow the product to come into contact with water so as to avoid any possible accidents that may result from a short circuit.
- If the mains cable or plug is damaged, do not disassemble and attempt to repair it by yourself. Please contact your distributor.
- Ensure that the mains power is suitable for this product.
- Please disconnect the product from the mains supply after use or before cleaning to avoid damage to the equipment or personal injury.
- Please use this product according to this Manual.
- Do not use any spare parts and attachments other than those recommended.
- Do not use this product if its casing or mains cable is damaged.
- Do not use this product if you are under the influence of alcohol or feeling unwell.
- Do not use this product with too much force so as to avoid injury.
- Do not keep this product on for more than 15 minutes so as to avoid overheating.
- Do not use this product within one hour of eating.
- Please use this product carefully according to your doctor's advice if you have a neck or back injury or if you have had an operation recently.
- Weighing more than 100kg are prohibited

2. WORKING ENVIRONMENT

- Do not use this product in a highly humid environment such as a bathroom.
- Do not use this product immediately after there has been a sharp change in the environmental temperature.
- Do not use this product in an environment where there are lots of dust or corrosive gases.
- Do not use this product when it is covered by a blanket or pillow, etc.

3. PEOPLE THAT SHOULD NOT USE THIS PRODUCT

- People with contagious skin conditions
- Patients with osteoporosis
- Patients with heart diseases and with electronic medical instruments like a heart pacemaker
- People in a high fever
- Women that are pregnant or menstruating
- Those who are injured or suffering from any body surface disease
- The appliance has a heated surface. Persons insensitive to heat must be careful when using the appliance.
- Children under 14-year old or people mentally unbalanced without being supervised are not allowed to use this machine.
- Those who to need rest according to a doctor's advice or those who do not feel well
- Do not use this product when you are wet
- Do not use this product on a pet.

Safety And Maintenance

4. SAFETY PRECAUTIONS

- Do not plug or unplug this product when your hands are wet
- Do not pull the cable when unplugging. Do not plug or unplug carelessly.
- This appliance is not intended for use by persons (including children) with reduced physical, sensory or mental capabilities, or lack of experience and knowledge, unless they have been given supervision or instruction concerning use of the appliance by a person responsible for their safety.
- Children should be supervised to ensure that they do not play with the appliance.
- Do not damage the cable or change the circuit of the product.
- Please cease using this product in case of a power cut in order to avoid any body injury upon sudden power resumption.
- Please stop using this product and consult your local supplier if you notice anything abnormal with the product during use.
- Please stop using this product and consult your doctor for advice
- If the supply cord is damaged, it must be replaced by the manufacturer, its service agent or similarly qualified persons in order to avoid a hazard.
- The appliance has a heated surface. Persons insensitive to heat must be careful when using the appliance.
- Forbidden to use when the cover broken.
- Forbidden to press it with stronger force or by whole body, don't touch it with hard objects, don't put it under heavy stress or tread on it.
- Prevent water or other corrosive liquid inflow to the products and cause stoppage and damage the machine.
- Please don't touch the wire line or controller line with hand, it may be cause the machine suspension and swing, lead to stop working because of the wire core was broken.
- Please don't change the structure of the machine or replace the spare parts.
- Keep it away from fire or inflammable place, it is more prone to stoppage and danger, cause distortion, discolored or damaged.
- If any abnormal happens when using, please stop it and cut off the power.
- People who mentally unbalanced or paralyzed should be carefully to use and under the watchful eye of others or consult to the doctors before use.

WARNING

In order to avoid product's damage or body injury by rolling over, it is prohibited to stand on one side of this product or jump on it.

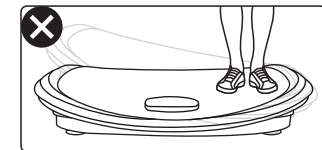
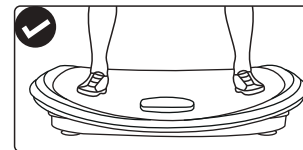

Name And Function

Wireless controller watch type

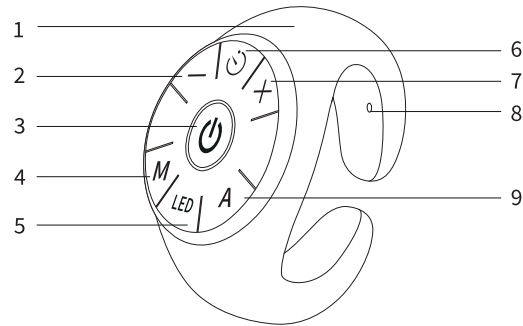

- 1.Watch ring
- 2.Speed -
- 3.ON/OFF
- 4.Manual
- 5.LED switch
- 6.Timing
- 7.Speed +
- 8.Infrared emission lamp
- 9.Auto

Machine description

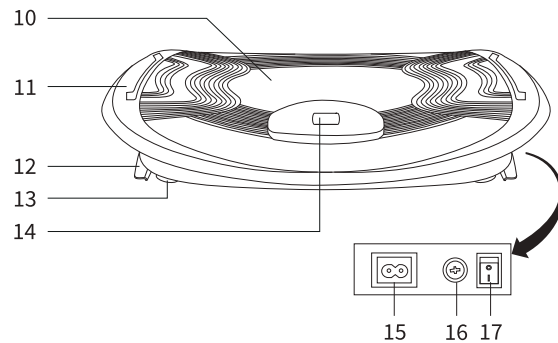

- 10.Pedal
- 11.Body
- 12.Fitness elastic rope
- 13.Non-slip rubber mat
- 14.Digital screen
- 15.Power interface
- 16.Fuse
- 17.Power switch

Machine button description

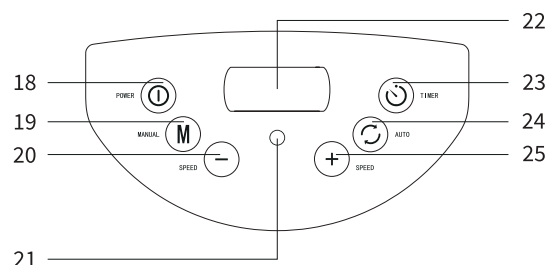

- 18.On/off
- 19.Manual
- 20.Speed -
- 21.Infrared window
- 22.Digital screen
- 23.Timing
- 24.Auto
- 25.Speed +

Name And Function

Accessories



Function







1. Use swing + shaking mode to achieve models the bodyeffect. 5 minutes of exercise is equivalent to running 1km.
2. The unique arc pedal design (patent) makes the effect of movement better.
3. The timing can be adjusted during 5-30 minutes,the default time is 15 minutes.
4. 6 automatic modes and 15 manual modes can be chosen as request.
5. Adopt DC24 V double motor, safe and reliable.
6. With fitness elastic rope, can do a variety of sports posture.
7. LED lights on both sides.
8. Wireless controller watch .

Operation guide



- Please read the following matters carefully before using this product. The product only uses power AC100-240V-50/60Hz,so please check the home voltage whether is consistent with the specifications of the product label.
- The AC power plug to the power socket, and start the main power switch.
- Standing on pedal pad, please press power switch button which locate in control panel or power switch in remote controller, start default massage function. Please use the remote controller if you need other massage function.

Operation guide

1.Machine buttons





Button	Function description	Display
	On/off:start with the default auto mode “R3”, the timing is 15 minutes.	
	Speed +: the movement speed can be adjusted (1-15levels)	
	Speed -: the movement speed can be adjusted (1-15levels)	
	Auto mode:When the current mode is not auto mode: switch to auto mode "A";When the current mode is auto mode : the auto mode can be switched . <div style="display: flex; justify-content: space-between;"> <div style="width: 45%;"> <ul style="list-style-type: none"> R01 Automatic shake 1 R02 Automatic swing1 R03 Automatic (shake, swing, shake + swing) </div> <div style="width: 45%;"> <ul style="list-style-type: none"> R04 Automatic shake2 R05 Automatic swing2 R06 Automatic (shake, swing, shake + swing) </div> </div>	
	Manual mode:When the current mode is not manual mode: switch to manual mode "H";When the current mode is manual mode : the manual mode can be switched . <ul style="list-style-type: none"> H01 Automatic shake H02 Automatic swing H03 shake + swing 	
	Timing : 5-30 minutes for choose, press each once to add 5 minutes.	

2.Wireless remote controller-wrist watch band type

Button	Function description
	On/off:start with the default auto mode “R3”, the timing is 15 minutes.
	Speed +: the movement speed can be adjusted (1-15levels)

Operation guide

2.Wireless remote controller-wrist watch band type

	Speed -: the movement speed can be adjusted (1-15levels)
	Auto mode : can be switched to control auto mode ,shake, swing, shake plus swing
	Manual mode : can be switched to control manual mode ,shake, swing, shake plus swing
	LED switch :control the LED light on and off .
	Timing :timing is 5-30 minutes, press each once to add 5 minutes.

The method of usage

Three kinds of different ways of movement (different auxiliary equipment can be selected during sports, such as magic pull rope, dumbbell)

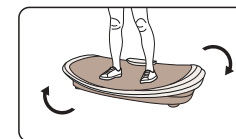

shake

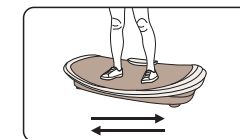

swing

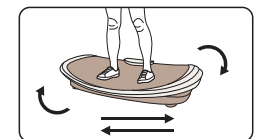

shake + swing

- 1.Shake mode:low exercise ,help to relax the leg muscles ,promote the leg blood circulation.
- 2.Swing mode:medium exercise,alleviate the leg muscles and nerves, achieve fitness effect at the same time .
- 3.Shake + swing mode:high exercise,whole body exercise ,consume more energy , promote blood circulation.

The method of usage

Natural movement pattern (walking, jogging, run three grades can be free to choose)

- Standing way (legs stand on the machine) relaxes the leg muscle, promote leg blood circulation.

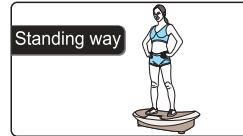

- Lying way (Adopt elbow support, abdominal hard straight, back, buttocks and feet in a line) shaping healthy body curve, to prevent subcutaneous fat ptosis.



- Sitting and standing stretch movement (sit on the machine , arms up and gassho above the head) Yoga movement, directly to the abdomen, buttocks fat, slim waist, lift the hips.



- Relax shoulder movement (sit on the machine, Hands back Open) alleviate the shoulder and neck muscles, ease the discomfort of per arthritis of shoulder and shoulder back, very suitable for white-collar.

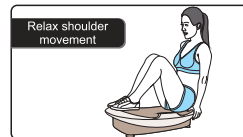

- Relax leg movement (sit on the chairs , put feet on the machine) Can quickly promote the leg blood circulation, relieve leg varicose veins, very suitable for the elderly.



The method of usage

Magic pull rope movement pattern (walking, jogging, run with three grade can be free to choose)

- Balance pulling way (clenched magic rope with your hands, arms flat, standing in run district)high frequency vibration in the arms, hips and legs, effectively lose inside the arm fat, improve the periartthritis of shoulder and neck soreness, coordination and balance.



- Left and right stretch way (clenched magic rope with your hands, left / right arm held flat to the opposite direction traction)vibration in the leg and traction body from left / right, effective stretching meridians, consumption of the body on both sides of abdominal fat, shaping healthy body.

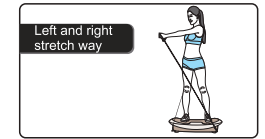

- Crouch way(left leg or right leg forward arch, right leg or left leg backward, both hands to lift the magic rope) to exercise the leg muscles and knee, increasing bone density in the leg, contribute to the cardiorespiratory exercise.



- Crouch pulling way (the legs slightly bent, hands along the back pull rope to lift the magic.)increase the pressure of the calf and knee, hip joint exercise, stretching back channels, improve the “computer arm ,mouse hand ”



- Standing way (standing in jogging/run district, to pull magic rope with your hands)exercise the arm joints and muscles, promote cervical vertebra corrective and systemic blood circulation; relieve muscle soreness of shoulder and back.

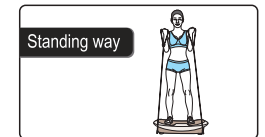

- Please unplug all the power wires , then raise one end of the machine to proper angle (The CG falls on the pulley) , Then can move forward or back , after move put back the machine to the Normal angle .



In the magic rope mode of motionalso can use dumbbell substitution (as follow chart)



Note:The above movement is not unique, different people according to their own needs, choose a different movement pattern.

Automatic program guide

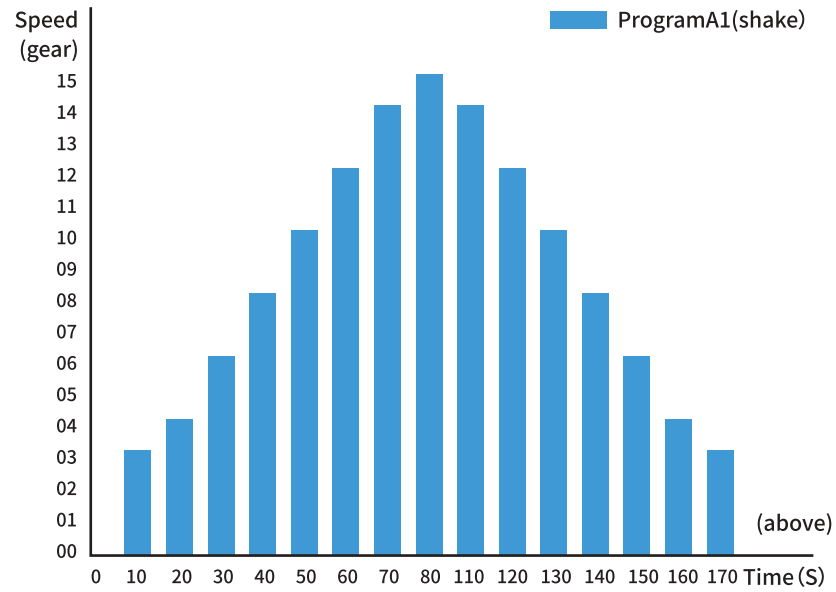

Automatic program guide

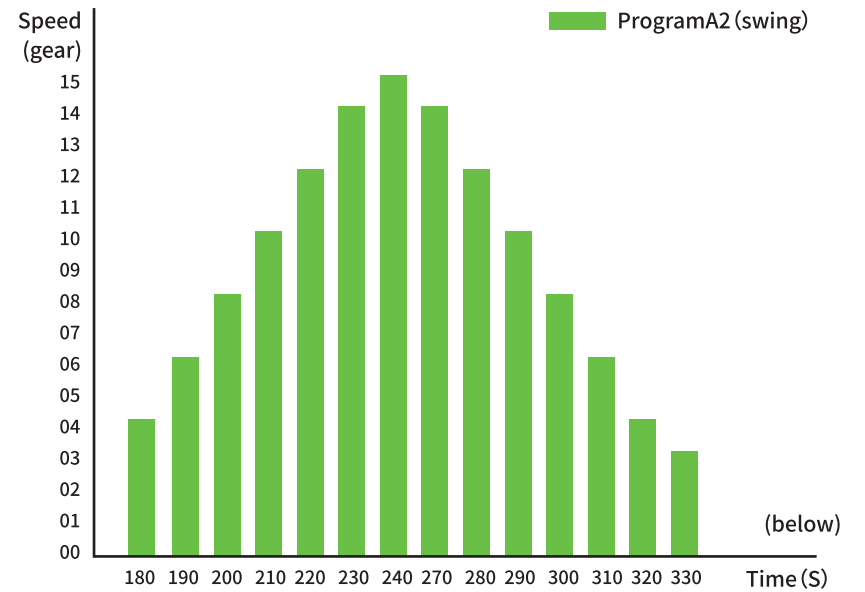
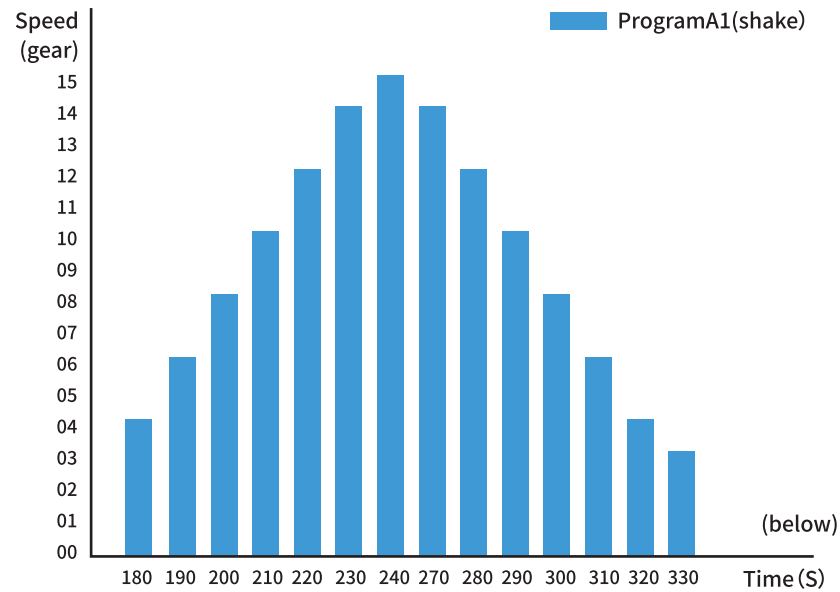
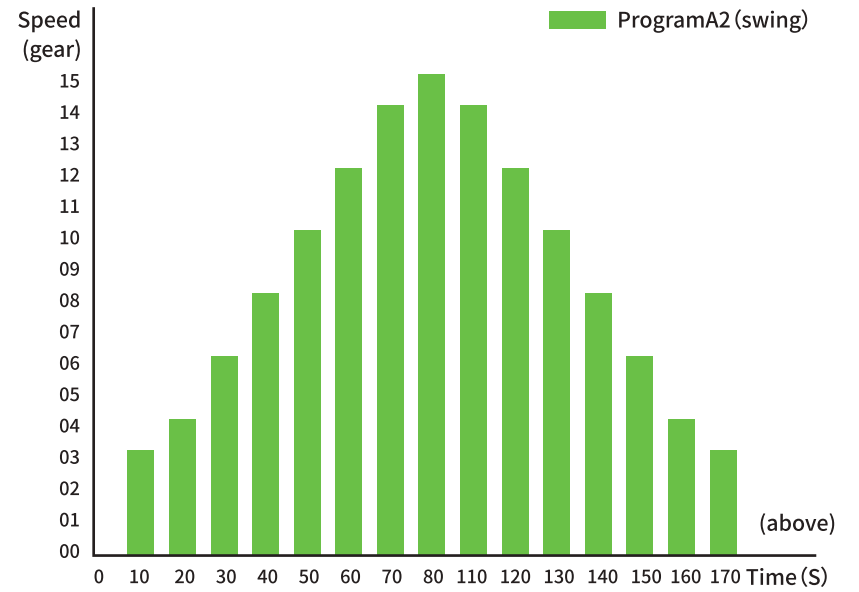

Automatic program guide

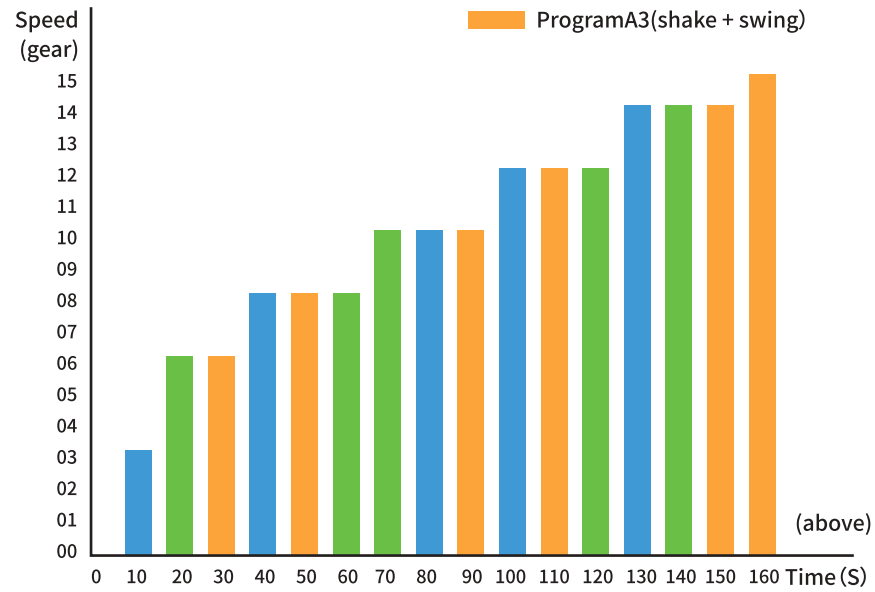

Automatic program guide

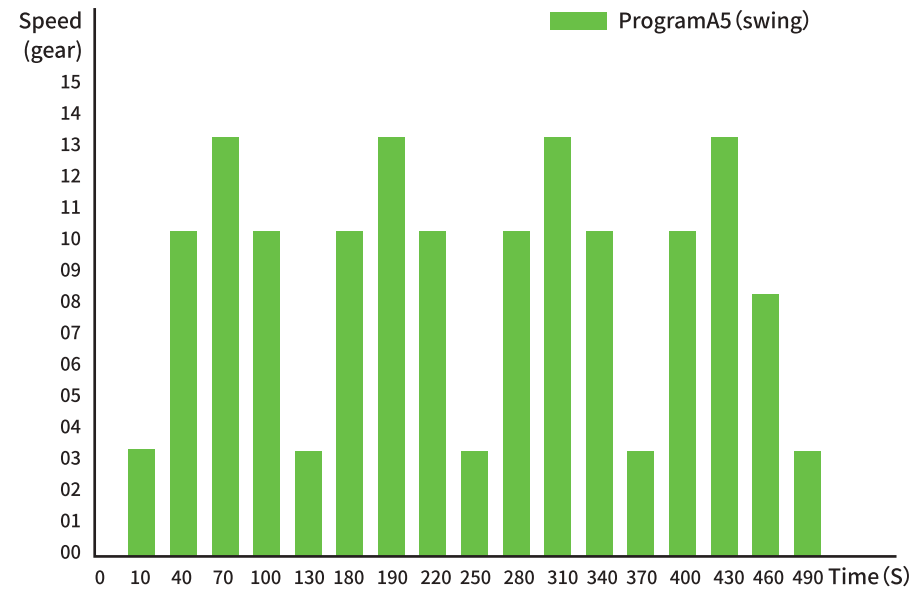
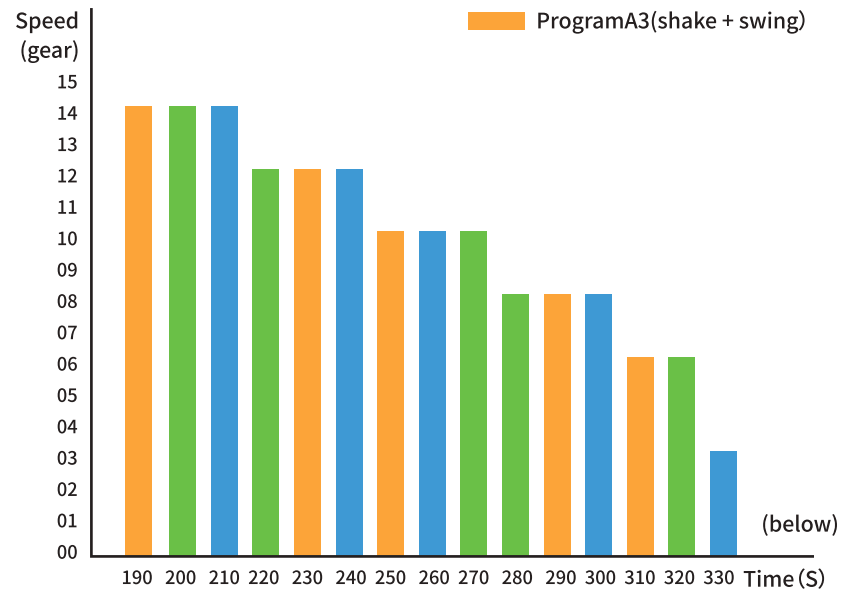
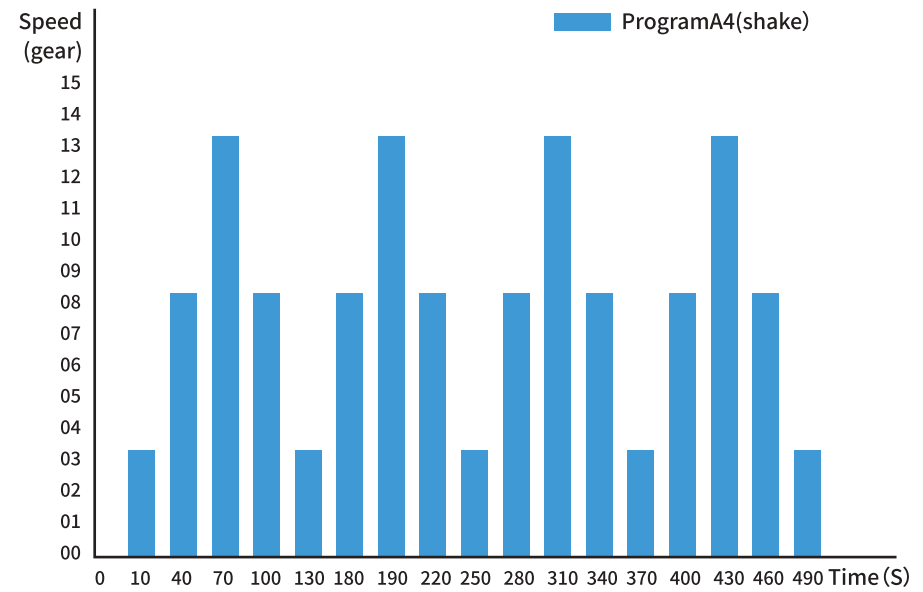

Automatic program guide

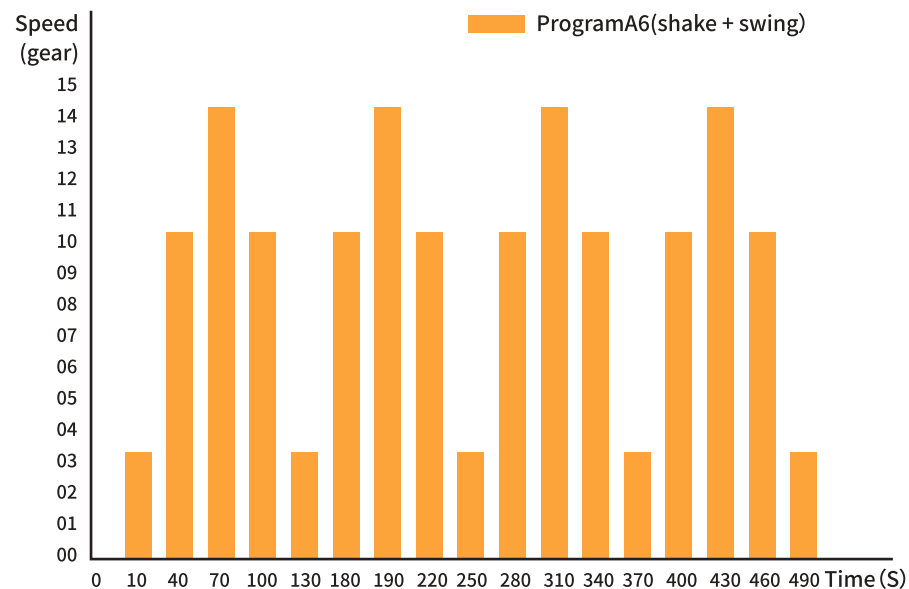

Maintenance

- If your product for shipping, handling and other reasons or stored in low temperature environment for too long, please stay in room temperature for one hour before use.
- If the product is placed in the special environment such as: local vulnerable to dust, moisture, sulfur compounds such as erosion, please notify the installation personnel to do the protective measures, otherwise it may cause body damage.
- Before cleaning products, please pull out the power plug from the socket.
- Do not use benzene, thinner or any erosion of the solvent cleaning machine.
- Please use dry cloth to clean the machine.
- Do not be the product of long-term exposure to sunlight, do not near the fire, high temperature place.
- If there will be a few days not to use this product, suggest the power extracted away and tidily store.
- Keep this product in a clean and dry space.
- Do not eat in the product, in order to avoid damage to the product.
- Storage conditions: at -10°C to 55°C, humidity for RH 0-85%.

Remote control COMS installing

1. Insert the COMS into remote controller
2. Tighten the screws in rear cover

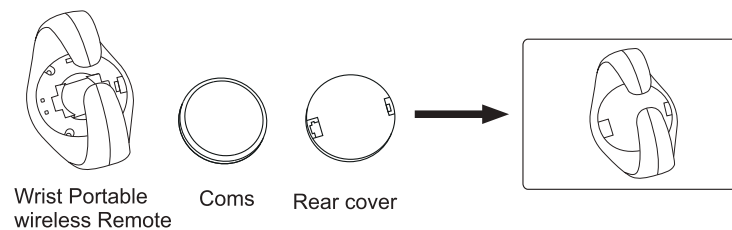

Remark: pay attention to the reset button hole when installing rear cover

Troubleshooting

You may meet following issues when using this machine, if below info can't help you to solve, please do contact seller to get professional maintenance.

Issue	Solution
No display on screen	To check the power cable well connect the product and switch on
Whole product doesn't work	Please check the voltage is suitable for this machine
	Switch off the power switch, disconnect plug, cool down the machine and try again 1 hour later.
Noisy when working	It is normal sound which is caused by the mechanical structure of the appliance.
Wrist controller out of control	First of all, pair the code of the wrist controller with the machine, it can work after the code paired
	If can't pair code, please check the COMS, if COMS out of battery, please insert new COMS and try again.

Specification

Model:Y21-1

Name:Body show magic machine

Rated voltage:100V-120V~ 50/60Hz
220V-240V~ 60Hz

Rated power:140W

Maximum load:120kg

Rated time:5~30minutes

Noise:≤55dB

Safe Design: